



*SERVING THE FOOD INDUSTRY SINCE 1951*

# ELECTRIC TOMATO SQUEEZERS

Item: 18901 Model: TS-IT-0110-S | Item: 18902 Model: TS-IT-0110-M | Item: 18903 Model: TS-IT-0110-L

## **SQUEEZE TOMATOES THE MOST EFFICIENT WAY**

Omcans electric tomato squeezers enable extraction of large quantities of tomato puree, separating it from seeds and skin.



**WARRANTY**  
PARTS AND LABOR

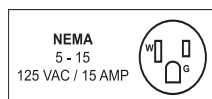

Authorized Dealer

### TECHNICAL SPECIFICATIONS

ITEM NUMBER	18901
MODEL	TS-IT-0110-S
DESCRIPTION	Electric
POWER	0.3 HP
WORM RPM	110
ELECTRICAL	115V/60Hz/1Ph
WEIGHT	20 lbs. / 9 kg.
PACKAGING WEIGHT	21 lbs. / 10 kg.
DIMENSIONS (DWH)	20.5" x 9.5" x 14" / 521 x 241 x 356 mm
PACKAGING DIMENSIONS	16" x 9" x 11" / 406 x 229 x 279 mm



### Features:

- 0.3 Horsepower
- Worm and body is resin with double hot tinning
- Filter cone, funnel, and drip pan are entirely made of 18/10 stainless steel

### TECHNICAL DRAWING AND DIMENSIONS

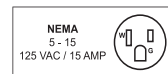
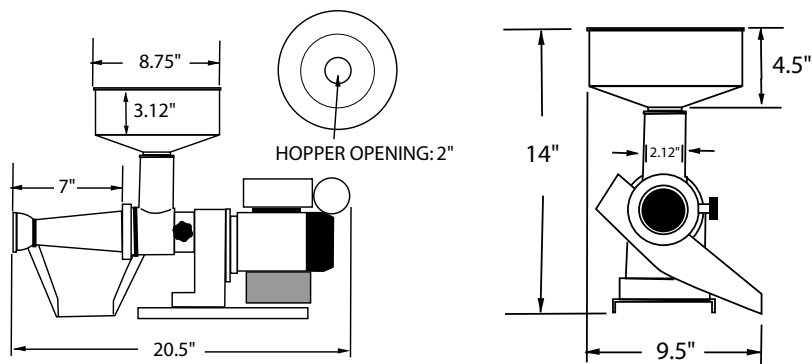

**OMCAN INC.**

Telephone: 1-800-465-0234

Fax: (905) 607-0234

Email: sales@omcan.com

Website: www.omcan.com



60

Follow us to keep up to date with the latest news and offers



### TECHNICAL SPECIFICATIONS

ITEM NUMBER	18902
MODEL	TS-IT-0110-M
DESCRIPTION	Electric
POWER	0.4 HP
WORM RPM	110
ELECTRICAL	115V/60Hz/1Ph
WEIGHT	31 lbs. / 14 kg.
PACKAGING WEIGHT	37 lbs. / 17 kg.
DIMENSIONS (DWH)	27" x 12" x 13" / 686 x 305 x 330 mm
PACKAGING DIMENSIONS	21" x 12" x 13" / 553 x 305 x 330 mm



### Features:

- 0.4 Horsepower
- Worm and body is resin with double hot tinning
- Filter cone, funnel, and drip pan are entirely made of 18/10 stainless steel

### TECHNICAL DRAWING AND DIMENSIONS

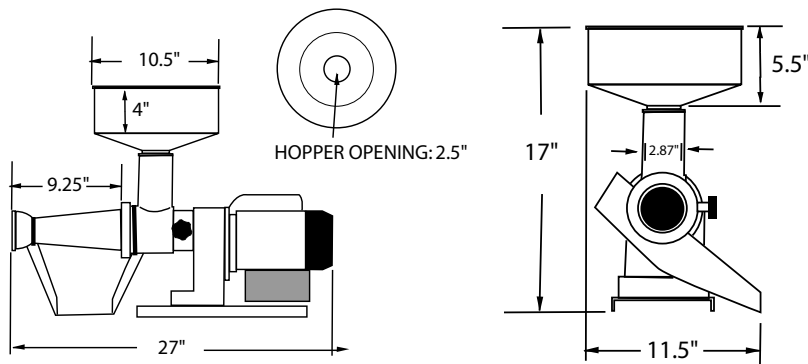

Optional Meat Grinder Attachment

ITEM NUMBER	DESCRIPTION
20170	# 12 Meat Grinder Attachment



**WARRANTY**  
PARTS AND LABOR



SHIPPED ON PALLET

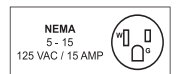

## OMCAN INC.

Telephone: 1-800-465-0234  
 Fax: (905) 607-0234  
 Email: sales@omcan.com  
 Website: www.omcan.com



60

Follow us to keep up to date with the latest news and offers



## TECHNICAL SPECIFICATIONS

ITEM NUMBER	18903
MODEL	TS-IT-0110-L
DESCRIPTION	Electric
POWER	0.8 HP
WORM RPM	110
ELECTRICAL	115V/60Hz/1Ph
WEIGHT	40 lbs. / 18 kg.
PACKAGING WEIGHT	43 lbs. / 20 kg.
DIMENSIONS (DWH)	28" x 11.5" x 17" / 711 x 292 x 432
PACKAGING DIMENSIONS	21" x 12" x 13" / 533 x 305 x 330 mm



### Features:

- 0.8 Horsepower
- Worm and body is resin with double hot tinning
- Filter cone, funnel, and drip pan are entirely made of 18/10 stainless steel

## TECHNICAL DRAWING AND DIMENSIONS

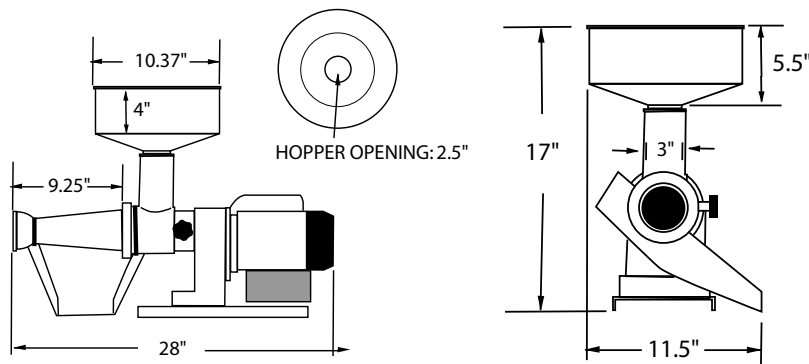

Optional Meat Grinder Attachment

ITEM NUMBER	DESCRIPTION
20169	# 22 Meat Grinder Attachment



**WARRANTY**  
PARTS AND LABOR



SHIPPED ON PALLET

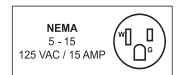

**OMCAN INC.**

Telephone: 1-800-465-0234

Fax: (905) 607-0234

Email: sales@omcan.com

Website: www.omcan.com



60

Follow us to keep up to date with the latest news and offers

